

Azuro

JET

Installation, Assembly and Operating Instruction Manual

1.1 Application

The equipment is designed for operation in private swimming pools. It is not intended for use in any public swimming pools and similar facilities.

The recommendations, data and information contained in this Installation, Assembly and Operating Instruction Manual should be strictly observed, as special requirements are placed on the pumps used in swimming pools.

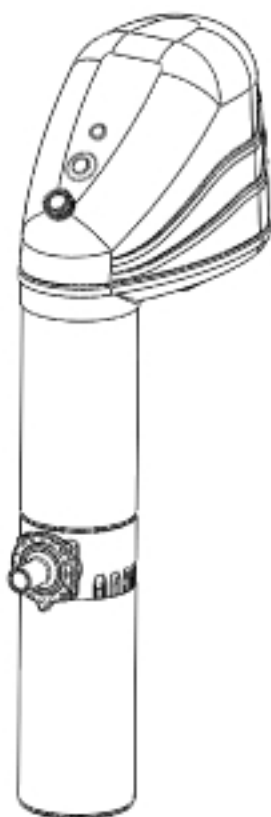

2. Safety

This Instruction Manual provides basic guidelines that shall be adhered to while installing, operating and maintaining the counter-flow system. That is why this instruction should be carefully read by both the relevant professionals and users and kept near the installed equipment to be available all the time.

All the safety instructions contained in this Manual shall be unexceptionally adhered to.

2.1 Indication of Particular Instruction in the Manual

The safety instructions set out in this Manual, whose non-adherence can result in personal hazard, are indicated using the following general symbol of hazard:



The safety instructions set out in this Manual, whose non-adherence can result in the risk of electric injury, are indicated using the following general symbol, warning of electric hazard:



The above safety signs comply with ČSN ISO 3864 Standard

The instructions shown directly on the equipment concerning, e.g.,

- the indication of the maximum permissible level, or
- the identification of connections

shall be unconditionally adhered to and the related signs/labels shall be kept perfectly clean.

2.2 Personnel Training and Competence

Persons that operate, maintain, inspect, or install the counter-flow unit shall be of proper professional qualification.

The scope of operator's responsibility, competence and control shall be clearly specified by the owner. In case the operators are not adequately qualified, they should get necessary training and instruction to meet the requirements.

Such training/instruction may be provided, e.g., by the manufacturer or dealer on equipment owner's request.

Further, the owner shall ensure the operator(s) to understand fully the contents of this Instruction Manual.

2.3 Hazards Caused by Non-Observance of Safety Instructions

Non-observance of safety instructions may result not only in a personal hazard, but it may also endanger the environment and/or the counter-flow unit itself. Any non-observance of safety instructions shall constitute the reason for the loss of any claim to damages.

In individual cases such non-observance may cause various hazards, such as:

- the failure of an important function of the machine or equipment;
- putting the operator or other persons at risk of electrical and/or mechanical injury;

- a threat to the environment;
- damage to the equipment and constructions.

2.4 Safe Working

Both the abovementioned safety instruction and applicable national safety regulations shall be adhered to.

2.5 General Instructions for Safe Equipment Operation

The protecting guards of moving equipment parts must not be removed from the counter-flow unit in operation as well as the equipment must not be operated without the guards being installed in position.

Any applicable regulation of law shall be observed.

Any risk of injury from electric shock shall be eliminated.

The swimming pool owner/operator shall provide for the orderly use of the pool by its users.

The counter-current unit may be used for the purpose of swimming and massaging only. In case the equipment is used in any other way or has been subjected to a modification not approved by the manufacturer, all and any manufacturer's warranties shall become void and inapplicable.

The water level in the swimming pool shall not extend higher than 300 mm above the delivery jet (see Fig. 1)

Ensure that the temperature of water in the swimming pool shall not exceed 30 °C.

2.6 Safety of Maintenance, Inspection and Assembly

Before carrying out any service/maintenance works on the Azuro Jet system, the counter-flow unit shall be switched off and disconnected from the power supply.

Procedures for putting the machine out of operation, as specified in this Instruction Manual, must be strictly and unconditionally observed.

Immediately after completing any works or inspection of the equipment, all its protecting and safety parts and devices shall be reinstalled and their functions restored.

Before restoring the equipment operation all the instructions laid down in the section dealing with the first putting of Azuro Jet into service shall be taken into account.

2.7 Wilful Modification and Production/Use of Replacement Parts

Any modifications or changes of the equipment shall be possible subject to the manufacturer's agreement only. Genuine replacement parts and accessories approved by the manufacturer will ensure equipment operational safety. The use of any other components/parts shall make the warranty void and shall relieve the manufacturer from any liability for possible consequences that might result from such action.

2.8 Misuse of the Equipment

Equipment operational safety shall be warranted provided that it is used in full compliance with this Instruction Manual.

It is forbidden to tread or sit on the equipment or on any of its parts.

It is not allowed to switch the pool lamp on, if not fully immersed in water. Failure to observe this advice could result in the candlepower reduction or even complete destruction of the lamp.

3. Transport and Storage

In order to avoid any damage to or loss of particular component parts do not open the original package but immediately before assembling the counter-flow unit.

4. Description

Azuro Jet suspension counter-flow units may be installed on all swimming pool types.

Water is taken-in by a turbine pump through a grating located in the lower part of its inlet tube. Then, water is pumped, by the turbine pump through a chamber and a mixing jet back into the swimming pool. Turbine pump operation is controlled by a pneumatic on/off push-button located on the unit housing. The volume of air taken in by the jet is regulated by a rotary control. The submersed counter-flow lamp is turned on/off by a light switch.

4.1 Contents of Delivery

- 1 AZURO JET counter-flow system for swimming pools
- 1 mounting plate for in-ground/partially in-ground swimming pools

4.2 Basic Optional Accessories

- Telescopic adjustable leg of the counter-flow system

4.3 Counter-Flow Unit Basic Parameters

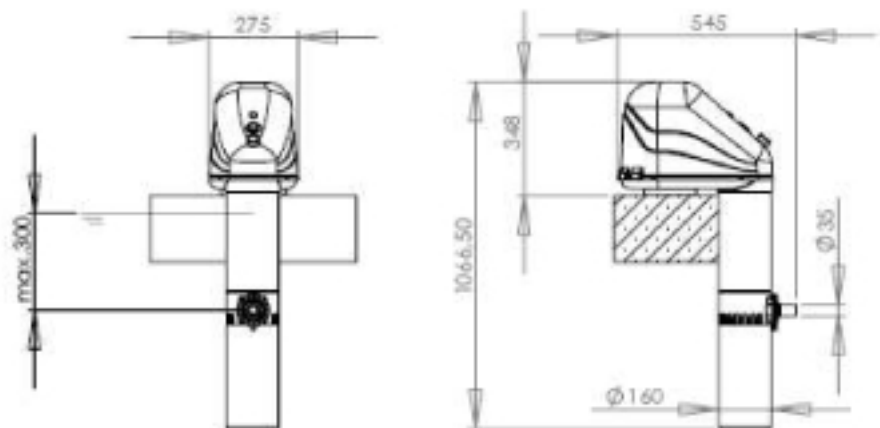

Fig. 1

Technical Specification (50 Hz)

Voltage	230 VAC (single-phase)
Pump capacity	~ 25 m ³ per hour
Power input	1,5 kW
Power output	1,1 kW
Jet tilt angle	60°
Control system	air operated

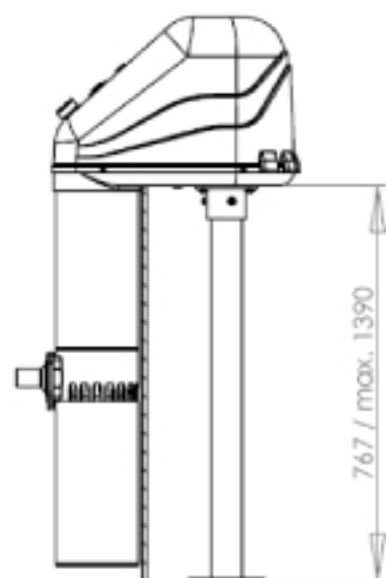

Fig. 2

5 Assembly/Installation

5.1 Installing the Counter-Flow Unit in an In-ground Swimming Pool

The mounting plate provided as a part of the delivery and attached to the counter-flow unit shall be used for installation.

- The counter-flow unit should be installed on a foundation plate made of concrete (B30) whose surface should be found 20 cm below the level of the swimming pool upper edge. In this configuration the counter-flow unit will stand on the perimeter rim of the pool.

- The upper cover of the counter-flow unit should be removed before commencing the installation

- The unit should be installed so that its cylinder tube is placed as close to the pool wall or edge rim as possible.

- The unit should be anchored to the foundation plate by means of M8-160 bolts (Fig. 3) using a chemical anchor system (i.e. two-component resin mortar designed for fixing mechanical parts to a mineral base). The bolts should be set in the concrete foundation plate to the depth of 138mm. The counter-flow unit should be fixed to the plate using $\varnothing 8.2$ mm washers and M8 locknuts. Neither the bolts, nor other anchoring material comprise a part of the delivery.





Fig. 3

5.1 Installing the Counter-Flow Unit in an Above-ground Swimming Pool

The telescopic adjustable leg shall be used for installation. That telescopic leg is not included in the delivery.

- The counter-flow unit should be installed on a foundation plate made of concrete (B30) whose surface should be found from 767cm to 1390cm below the level of the swimming pool upper edge. The telescopic leg should be then adjusted in length to lay the counter-flow unit on the pool upper edge.
- The upper cover of the counter-flow unit should be removed before commencing the installation
- The unit should be installed so that its cylinder tube is placed as close to the pool wall or edge rim as possible.
- The unit should be anchored to the foundation plate by means of M8-160 bolts using a chemical anchor system. The bolts should be set in the concrete foundation plate to the depth of 138mm. The counter-flow unit should be fixed to the plate using Ø8.2mm washers (wide type) and M8 locknuts. Neither the bolts, nor other anchoring material comprise a part of the delivery.

5.2 Electrical Connection

The counter-flow unit shall be connected to the power supply (mains) only after its body has been mechanically stabilised. The connection may be carried out only by a properly qualified electrician certified to §6 of Regulation 50/1978 Sb.

See Fig. 4 for the wiring diagram.

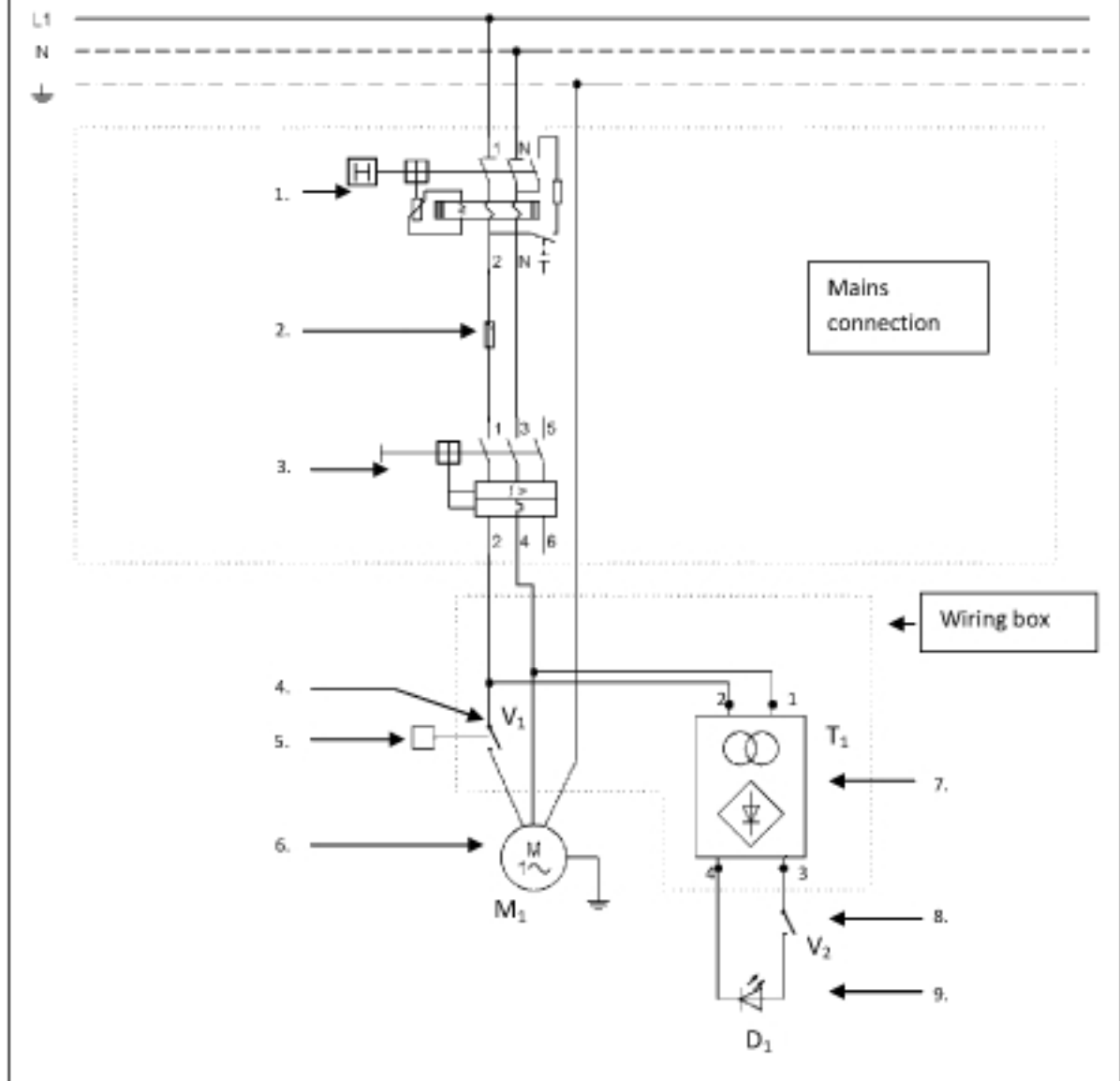

Fig. 4

10. Overcurrent circuit breaker, $I_{f} \leq 30 \text{ mA}$, 16A
11. Fuse 16 A, quick acting
12. Motor starter, two-pole, 6-10 A
13. Pressure switch
14. Pushbutton switch control
15. Pump motor
16. Protective transformer with a rectifier
17. Switch
18. LED light



The counter-flow unit should be connected to the mains supply *via* the motor starter, the fuse and the over-current circuit breaker. See the wiring diagram for specification. Failure to install those safety devices poses a threat to the public and may result in an electric injury. Hose devices shall be located outside of the pool protective area (formed by zones 0, 1 and 2) to ČSN 33 2000-7-702 Standard, which extends to the distance of 3.5m from the pool perimeter wall, see Fig. 5.

- The devices shall be installed in a lockable cabinet to be protected from any unauthorized tampering.

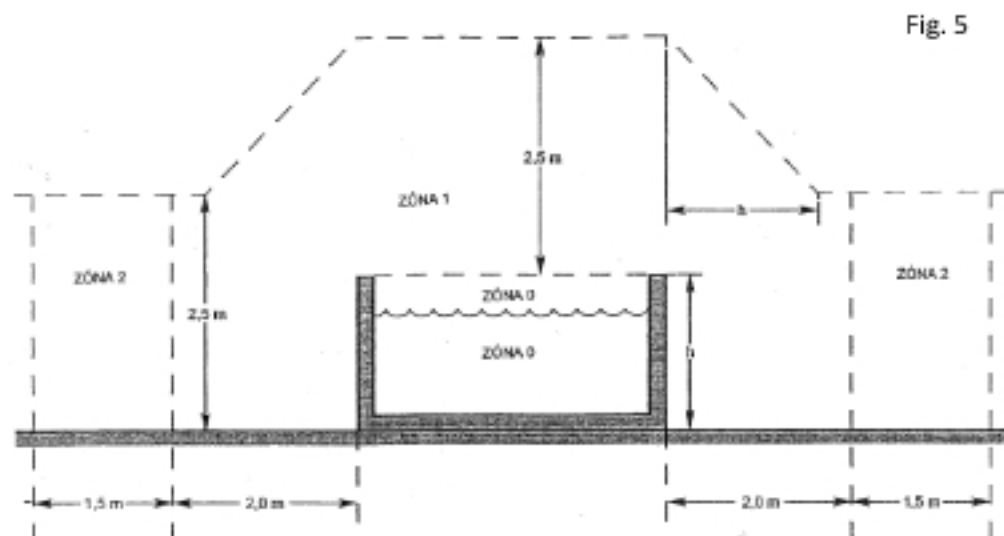

Fig. 5

- For connecting the inlet cable to the counter-flow unit cable distribution box see Fig. 6.

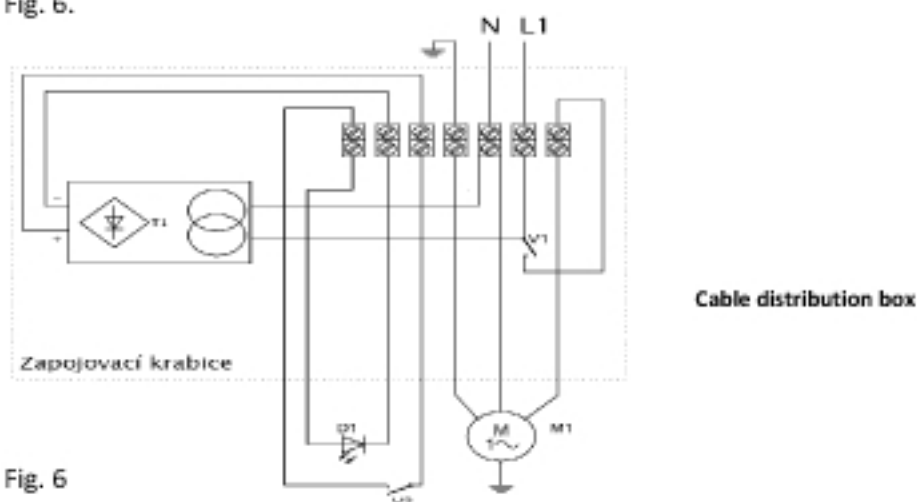

Fig. 6

- The inlet cable of $3 \times 1.5 \text{ mm}^2$ size should be passed through a grommet installed in the lower cover, as shown in Fig. 3. In the box the cable shall be locked in position by a clamp provided. The cable should be led to the counter-flow unit in a cable protector.



- The counter-flow unit must be properly earthed by a grounding cable. The grounding cable eye shall be connected to the grounding bolt found in the lower part of the motor housing.

- After connecting the unit to the mains supply its upper cover shall be reinstalled.

6 Putting into Operation and Control

- After being mechanically anchored, connected to the mains supply and reinstallation of the covers the equipment is ready for putting it into operation. The counter-flow unit is started using the pneumatic push-button shown in Fig. 6. The equipment is vented automatically

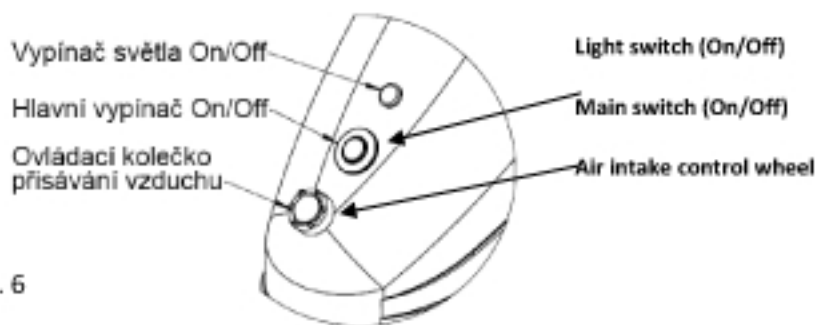
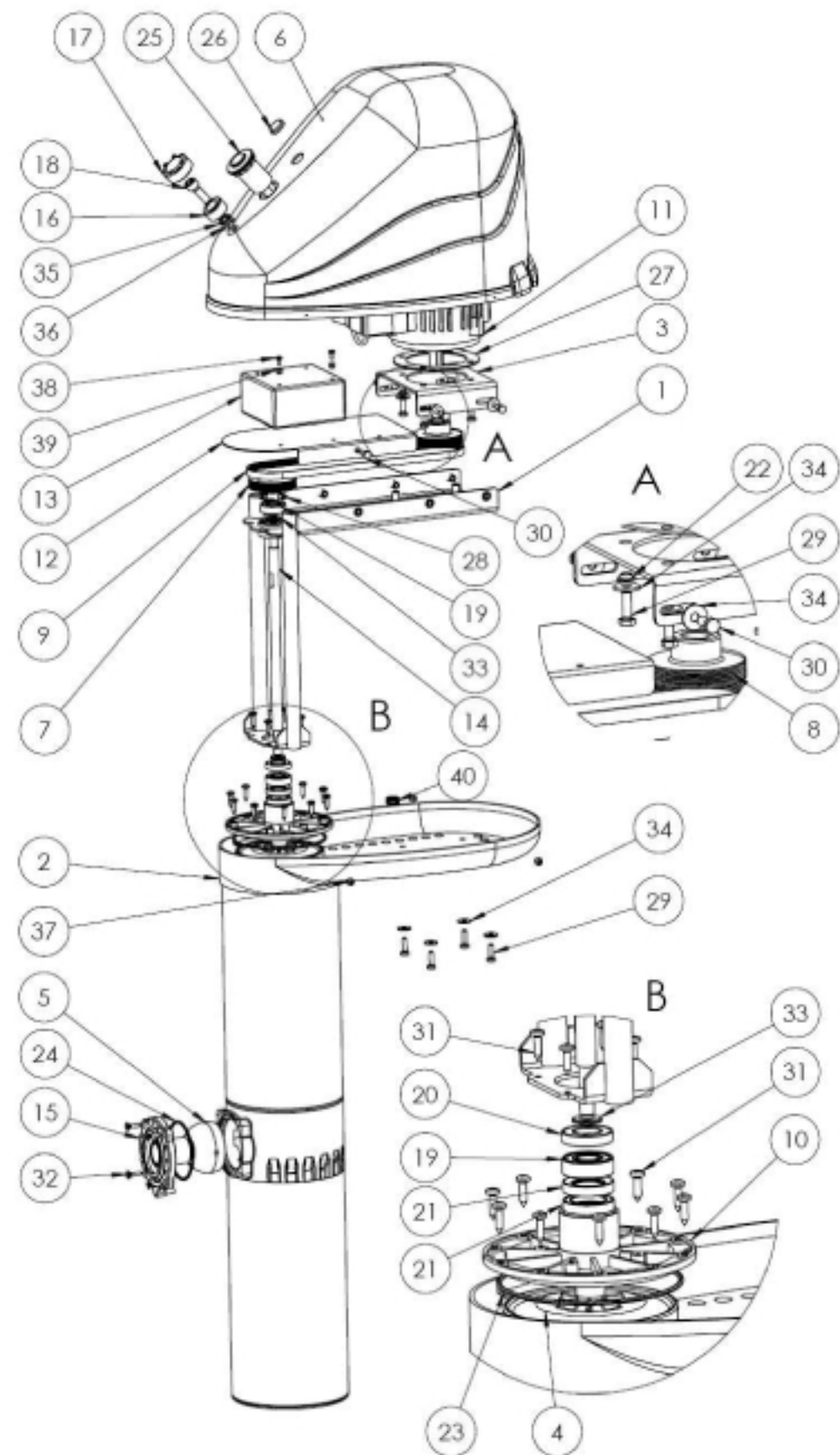

Fig. 6

8 Maintenance, Preparation for Winter Season

- The counter-flow unit does not require any special care or maintenance, as it is almost maintenance-free. However, attention should be paid to the clarity/purity of water in the pool in order any fouling to be avoided of the intake grid or even of the pump casing.

- For winter season it is recommended the counter-flow unit to be removed from the pool and stored at a dry place. However, the equipment can be left installed outdoors provided that no equipment part remains immersed in water. If the counter-flow unit is to be left outdoors, its motor starter has to be switched off.



	Pcs	Name
1	1	Supporting frame
2	1	Counter-flow unit body
3	1	Motor bracket
4	1	Impeller assembly
5	1	Jet assembly
6	1	Cover 2 – upper one
7	1	Pulley 1
8	1	Pulley 2
9	1	Drive belt PJ711/4
10	1	Pump cover
11	1	Motor - Cemot 1,1 KW
12	1	Wiring box supporting plate
13	1	Wiring box
14	1	Shaft
15	1	Jet cover assembly
16	1	Air intake nut
17	1	Air control wheel
18	1	Air intake bolt - M10x30
19	2	Bearing 6202 2RS
20	1	Simmering (Gufero) 15x35x10
21	2	Simmering (Gufero) 20x35x10
22	4	GFM-0608-5
23	1	O-ring 125x4
24	1	O-ring 79x4
25	1	Pneumatic push-button
26	1	Lighting switch
27	1	Insulating washer
28	1	Lock ring B DIN 472 35x1.5 A
29	8	Bolt DIN 933 M6x20
30	6	Bolt DIN 933 M6x16
31	14	Bolt ST4,8x19-C-Z ISO 7050
32	4	Bolt ST4,8x22-C-Z ISO 7051
33	2	Washer DIN 125 1 B 10.6
34	12	Washer DIN 9021 6.5
35	1	Washer DIN 6798 A 10.6
36	1	Nut DIN EN 24035 M10
37	4	Bolt ST4,8x9-C-Z ISO 7050
38	2	Bolt ISO 4017 - M4 x 8-N
39	2	Nut ISO 7040-M4-N
40	1	Grommet Ø8 (for metal sheet)

The Azuro Jet counter-flow unit for swimming pools complies with the following international standards:

EN 809 – Pumps and pump units for liquids. Common safety requirements

EN 60335-1 – Household and similar electrical appliances - Safety -Part 1: General requirements

EN 60335-2 - Household and similar electrical appliances - Safety –Part 2-41: Particular requirements for electric pumps for liquids having a temperature not exceeding 35 °C

EN 50081-1/2 (EMC) Electromagnetic compatibility. Basic specification “Emitted Interference”

EN 50082-1/2 (EMC) Electromagnetic compatibility. Basic specification “Emitted Interference”

IEC 60364-7-702 – Electrical installations of buildings - Part 7: Requirements for special installations and locations – Section 702: Swimming pools and other basins